

NOBLE GAS AIR/STACK MONITOR ARGON – XENON – KRYPTON

Model # FM-9XE-NG

Model # FM-9NGAS-2

Model # FM-9NGAS-3

惰性气体空气/烟囱道监测器

氩 - 氙 - 氪

FEATURES:特点

- NEW, IMPROVED DIGITAL XENON MONITOR
新款改进型数字氙监测器
- USER FRIENDLY
用户友好界面
- SIX-DIGIT READOUT
六位数读数
- AIRBORNE CONCENTRATION & TOTAL DOSE IN Bq/l
气载浓度&总剂量单位 Bq/l
OR IN MPC (OR ANY UNITS)
或 MPC (或任何单位)
- SETTABLE ALARMS
可预设报警
- COMPUTER INTERFACE USB OR ETHERNET
计算机接口 USB 或以太网
- DATA LOGGER BUILT-IN
内置数据录入



APPLICATION:应用

The **FM-9XE-NG** Monitor is fast becoming the first choice for Noble Gas measurement in facilities all over the world.

FM-9XE-NG 监测器正在快速成为全世界各种设施惰性气体测量的首选。

DESCRIPTION:描述

Model **FM-9XE-NG** - Noble Gas Monitor determines noble gas content of air by drawing the air through a gas chamber which is under constant surveillance by a radiation detector. It is normally supplied with a six foot outlet and inlet hose so that it may draw air from the use area, duct, stack, glove box, hood or filter trap. In addition to showing the noble gas content on the monitor. All data is recorded on internal memory. It can also furnish permanent record in the form of an **optional** CD/DVD writer or digital printer with date & time stamp. An alarm is included which produces a red flashing light and/or 2,000 Hz (beep) should the preset level be exceeded.

型号 The **FM-9XE-NG** 惰性气体监测器通过一个在辐射探头连续监视下的气室抽取空气，判断空气中惰性气体含量。通常配有一条 6 英尺长的输出和输入软管，以便从被使用区域，风管，烟囱道，手套箱，风罩，过滤器中抽取空气。显示器除了显示惰性气体含量外，所有数据被内置内存收录，也可以用可选购的 CD/DVD 机或带日期的数字打印机永久保存记录。包括一个报警器，如果超过预设值提供红闪并/或发出 2,000Hz (蜂鸣音)。



1160 US ROUTE 50
MILFORD, OHIO 45150-9705
TELEPHONE (513) 248-2400
FACSIMILE (513) 248-2402
E-MAIL sales@overhoff.com
WEB www.OVERHOFF.com

SPECIFICATIONS 规格

- Sensitivity:** 5 x 10⁻⁹ µCi/cc – See Chart
灵敏度: 5 x 10⁻⁹ µCi/cc-见表

 - Fast Count:** Digital rate meter range FM-9XE-NG, 4 decades 0.1 mpc (10⁻⁶µCi/ml to 1000 mpc (10²µCi/ml)
快速计数: 数字率表量程 FM-9XE-NG, 4 进制 0.1 mpc (10⁻⁶µCi/ml-1000 mpc (10²µCi/ml)

 - Detection:** Gas chamber with 2" pancake GM detector (T-1190).
检测: 带 2"扁平 GM 探头气室 (T-1190)

 - Shielding:** 3/8" thick lead around chamber and detector. (7" H x 4.5" dia.)
屏蔽: 室和探头周围 3/8"厚铅。(高 7" x 直径 4.5")

 - Flow Rate:** Regulated - normally set at 10 Liters/minute.
流量: 调节-正常设定 10 升/分钟.

 - Pre-filter:** Used to remove particulates.
前置滤网: 用于移除粒子

 - Case:** Electronics housed in enameled metal case; 11" x 11" x 15".
箱: 电子学封装 在 11" x 11" x 15"的漆面金属箱里。

 - Display:** 7" color LCD monitor. Built-in digital and graphics user data display.
显示: 7"彩色 LCD 显示器, 内置数字图形用户数据显示

 - Air Pump:** Long life low noise type oil-less; (6" x 6" x 10")
气泵: 长寿命低噪音无油 (6" x 6" x 10")

 - Alarm: 报警**
 - Audible: 2000 Hz beeper.
音频: 2000 Hz 蜂鸣
 - Visual: red flasher settable at any point on scale.
视觉: 量程上任意设定红闪
- Relay closure for users door lock or remote alarm 用户锁门或远程报警继电器闭合
- Power:** 115V, 60 Hz. Optional 230V, 50 Hz.
电源: 115V, 60 Hz. 可选 230V, 50 Hz

 - Weight:** Electronics 12lbs, Shielded Detector 22lbs, Pump 7lbs.
重量: 电子学 12lbs, 带屏蔽探测器 22 磅, 泵 7 磅

 - Shipping Weight:** 690 lbs. (FM-9NGAS-3)
装船重量: 690 磅(FM-9NGAS-3)

 - Options:** E-FLO – Electronic Flow Meter
选购: E-FLO –电子流量表。

SPECIFICATIONS: 规格

- Sensitivity:** In the case of elevated background
灵敏度: 在本底升高情况下



1160 US ROUTE 50
MILFORD, OHIO 45150-9705
TELEPHONE (513) 248-2400
FACSIMILE (513) 248-2402
E-MAIL sales@overhoff.com
WEB www.OVERHOFF.com

NOBLE GAS AIR/STACK MONITOR
ARGON – XENON -KRYPTON Model
 # FM-9XE-NG Model # FM-9NGAS-2 Model
 # FM-9NGAS-3

Count Time	N ¹⁶ Background	MDA FM-9NGAS-2 Ar ⁴¹ Concentration	MDA FM-9NGAS-3 ¹ Ar ⁴¹ Concentration
20 min.	2mR/hr	1 x 10 ⁻⁷ μCi/cc	5 x 10 ⁻⁸ μCi/cc
33 min.	4mR/hr	1 x 10 ⁻⁷ μCi/cc	5 x 10 ⁻⁸ μCi/cc
70 min.	8mR/hr	1 x 10 ⁻⁷ μCi/cc	5 x 10 ⁻⁸ μCi/cc
30 min.	0.01mR/hr	1 x 10 ⁻⁸ μCi/cc	5 x 10 ⁻⁹ μCi/cc
8 hr.	2mR/hr	2 x 10 ⁻⁸ μCi/cc	1 x 10 ⁻⁸ μCi/cc

DESCRIPTION

Read-out Units (Typical) 读出单位 (典型)

Measures 测量

New Upgraded Hardware 新升级硬件

Available options 可选项

FM-9NGAS

Bq/m³ μCi/cc, or DAC

Airborne Concentration 气溶胶浓度

Calculations by Imbedded Processor

On Board Data Logger

嵌入式处理器进行计算, 机载数据录入

Optional Electronic mass flowmeter 电子质量流量计

Noble Gas Monitor Comparison

	FM-9XE-NG	FM-9NGAS-2	FM-9NGAS-3
Chamber Volume	300 cc	1 liter	1 liter
Main Detector	2" dia T-1190 GM	2" dia T-1190 GM	2 ea 2" dia T-1190 GM
Shielding	3/8"	1.0"	3.0"
Background Subtract Detector	N/A	N/A	Duplicate 2" dia T-1190 GM
Weights (lbs)			
Electronics	12 lbs	12	12
Pump	7 lbs	14	14
Detector Shield	22 lbs	200	590



1160 US ROUTE 50
 MILFORD, OHIO 45150-9705
 TELEPHONE (513) 248-2400
 FACSIMILE (513) 248-2402
 E-MAIL sales@overhoff.com
 WEB www.OVERHOFF.com

**NOBLE GAS AIR/STACK MONITOR
ARGON – XENON - KRYPTON**

Model # FM-9XE-NG

Model # FM-9NGAS-2

Model # FM- 9NGAS-3

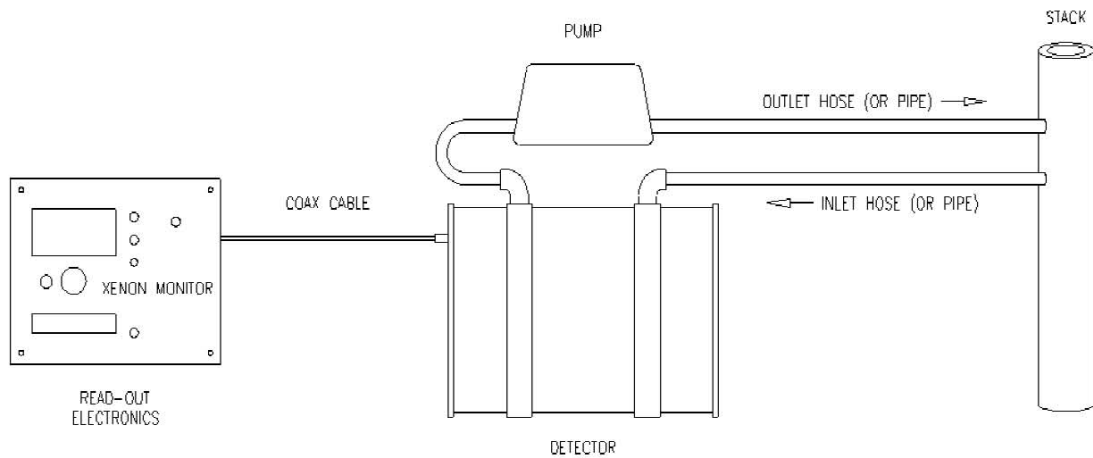

Quiet, long-life, Green-Turtle Pump



1160 US ROUTE 50
MILFORD, OHIO 45150-9705
TELEPHONE (513) 248-2400
FACSIMILE (513) 248-2402
E-MAIL sales@overhoff.com
WEB www.OVERHOFF.com